

CASE ERECTOR CE-11-P

The case erector CE-11-P forms cases with length up to 730 mm. The performance of the CE-11-P is also guaranteed when handling boxes with minimal carton thickness. Standard in hot melt execution, also available in tape execution.

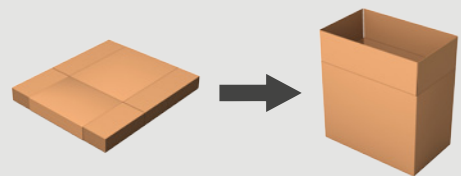

COMBINE WITH
**THE BAGMAKER
INSERTER**

Minimize your running cost

- Trouble-free case erecting even with **thin cartons**.
- Lower running cost and continuous production with hot melt.

Designed to be better

- **No more crushed cartons** thanks to the perfectly controlled case erecting.
- Guaranteed **box squareness** for a trouble-free packaging process.
- Only **5 adjustments** for a quick format change.



Watch our videos
at pattyn.com

TECHNICAL SPECIFICATIONS CE-11-P

Perfectly controlled case erecting

- The failsafe carton separator separates each carton individually from the magazine thanks to the unique up & down separation movement.
- Two opposing vacuum cups grip the blank at two sides for optimal carton opening.
- Less demanding on the box quality because the box is clamped at three sides during case flap folding.

Perfectly squared box

- The synchronised chain guiding system ensures a perfectly squared box.



Guaranteed closed bottom

- Downwards spraying of the nozzles, eliminates the risk of clogging.
- The upper and lower mechanical plunger bonds the case flaps firmly.

CE-11-P hot melt is standard equipped with:

- Nordson hot melt device
- Hot melt nearly finished: hot melt level detection enables refilling before hot melt is completely empty.
- Colour touch panel

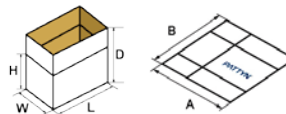
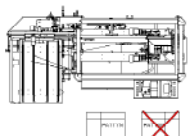
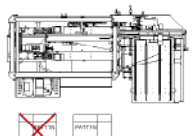
CE-11-P tape is standard equipped with colour touch panel

CASE DIMENSIONS (For other dimensions, please contact Pattyn)	
Range (L x W x H // D) mm	Min. 300 (L) x 200 (W) x 150 (H) // 250 (D) Max. 730 (L) x 500 (W) x 400 (H) // 650 (D)
Range (A x B) mm	Min. 500 (A) x 350 (B) Max. 1100 (A) x 900 (B)
	Length - height relation: $D/L < 1,3$ Outside dimensions
TAPE SPECIFICATIONS	
Type	2" inch
Tape roll length	990 m
Tape roll diameter	Max. 300 mm
TECHNICAL FEATURES	
Left 	Right 
	
OUTPUT AND CONSUMPTION	
Output hot melt	Standard up to 16 c/min, upgradeable to 20 c/min
Output tape	Standard up to 12 c/min, upgradeable to 16 c/min
Installed power hot melt	7 kW
Installed power tape	2,5 kW
Voltage	3 x 400 V + N + E / 50 Hz
Air supply	6 bar / 1/2"
Air consumption	35 NL / cycle
Weight	1150 kg
OPTIONS (more options are available, please contact Pattyn)	
Longer carton magazine: 2 m	
Ergonomic tape exchange with second taping head	
Access point for remote support	
Advanced stainless steel execution	
3" tape	

Pattyn Packing Lines nv
Industriepark 'Blauwe Toren'
Hoge Hul 2, 8000 Brugge - Belgium

T +32 (0) 50 450 480
info@pattyn.com
www.pattyn.com



Failsafe carton separator

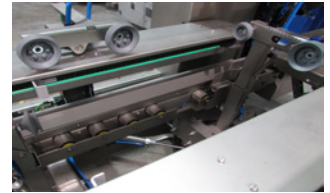

Box is clamped at three sides

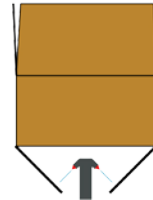

Synchronised chain system



Hot melt unit

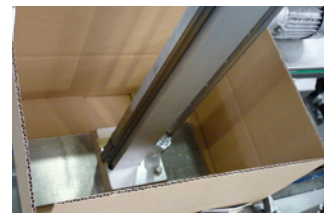

Mechanical plunger for perfect bonding

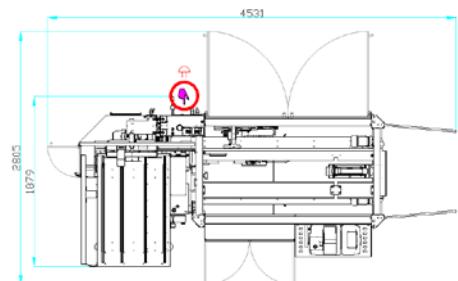

Machine height 1880 mm

The description, pictures and information given have an indicative value. We reserve the right to make changes without notice. Information and content is property of Pattyn. For customised executions please contact Pattyn. CE-11-P 2019 - V01