

BAGMAKER INSERTER FLEXIM-31

From a roll of polyethylene film, the high performance Flexim-31 automatically makes, cuts and inserts bags into cases, crates, trays, tins or pails. The Flexim-31 is **standard equipped with fully automatic format change.**

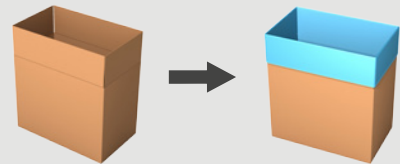

LOWEST
PACKAGING COST
USING BAGS
FROM A REEL

Minimize your bag cost

- **Save up to 30%** with made-to-measure bags from a reel.
- **Less film used** thanks to a perfectly controlled bag insertion.
- PE film starting from **10 µm**.

High performance & trouble-free production

- Up to **20 cases/minute**.
- Up to 4000 bags on one reel for **higher autonomy**.
- **Elimination of operator mistakes** thanks to the fully automatic format change.
- Quick and **ergonomic film roll exchange** from the operator side.



Watch our videos
at pattyn.com

TECHNICAL SPECIFICATIONS FLEXIM-31

Leakproof bag

- Impulse sealing for a controlled, clean and leakproof seal.

Failsafe bag opening

- Mechanical grippers instead of delicate vacuum cups.

Perfectly controlled bag insertion

- Case flap holders for perfect case flap positioning.
- Spoons with integrated air nozzle for gentle cuffing.
- Smart box lift for vertical box positioning.

Use of stepper motor technology

- High speed.
- Self-resolving.

Standard equipped with:

- Maintenance free V-shaped guillotine knife for a perfect film cut
- Colour touch panel for easy operation

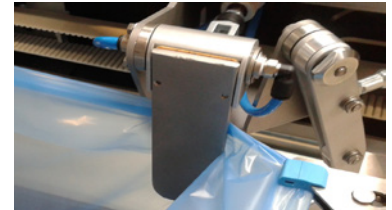

Spoons & mechanical grippers with air nozzle



Case flap holders



Controlled bag insertion



Optional thermo transfer printer

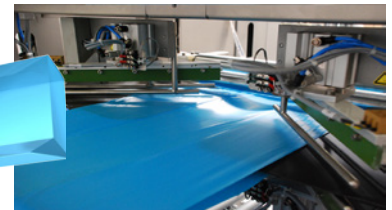

Optional corner seal unit 45°

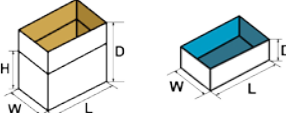
CONTAINER SPECIFICATIONS (For other dimensions, please contact Pattyn)	
Type	Cases, boxes, trays, crates, tins, pails, polystyrene cases, ...
Range (L x W // D) mm	Multi or mono footprint (LxW) / variable heights Min. 300 (L) x 200 (W) // 100 (D) Max. 800 (L) x 500 (W) // 650 (D) Outside dimensions
	*Cross seal unit 45° on both sides of the bag (150 < D < 460 mm)
*170 mm < D < 250 mm	Adapted bag cuff
*D < 170 mm	Modified box lift necessary
FILM SPECIFICATIONS	
Type	Tubular film with gussets (side folds)
Thickness	As from 10 µm
Weight of film roll	Max. 60 kg
Outside diameter film roll	Max. 450 mm
Inside diameter of core	76 mm
OUTPUT AND CONSUMPTION	
Output	Standard 14 c/min, up to 20 c/min
Installed power	4,5 kW
Installed power with cross seal unit	6 kW
Voltage	3 x 400 V + N + E / 50 Hz
Air supply	6 bar / 1/2" min
Air consumption	60 NI / cycle
Weight	900 kg
OPTIONS (More options are available, please contact Pattyn)	
Fast machine: speed above 14 to 20 c/min	Access point for remote support
Advanced stainless steel execution	Mechanical / Visual bag-in-box detection
Film roll trolley	Random case height modus
Cross seal unit to provide leakproof block bottom bag	
Thermo transfer printer for real time printing on bags (traceability)	
Integrated flaps down mechanism	
One line of sealing, two active sides of sealing wire	
Integrated air plunger for improved bag positioning	

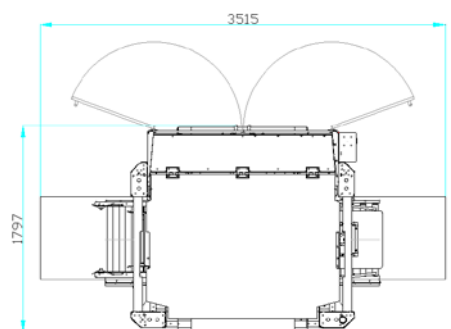

Machine height 1840 mm

Pattyn Packing Lines nv
Industriepark 'Blauwe Toren'
Hoge Hul 2, 8000 Brugge - Belgium

T +32 (0) 50 450 480
info@pattyn.com
www.pattyn.com



The description, pictures and information given have an indicative value. We reserve the right to make changes without notice. Information and content is property of Pattyn. For customised executions please contact Pattyn. Flexim-31 2019 - V01

PATTYN[®]

Turnkey solutions for industrial packaging.