

LINEAR VIBRATORY WEIGHFILLER LVF-15A-D

The LVF-15A-D one head linear vibratory filler offers the most suitable solution to weigh and fill **high volume products** such as margarine flakes and dehydrated & sliced fruit.

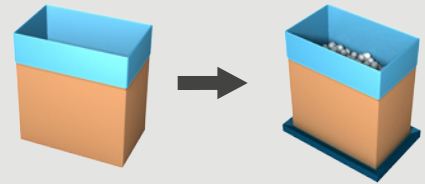

COMBINE
CONSTANT
FILLING WITH LOW
DROP HEIGHT

Easy to use & compact machine

- Your ideal solution for **easy and constant filling** up to 5 c/min.
- Hygienic design.
- Compact and low machine.

Gentle product treatment

- Gross filling **straight into the box** reduces drop height and number of drops.



Watch our videos
at pattyn.com

TECHNICAL SPECIFICATIONS LVF-15A-D

Easy weigh filling

- One big vibrating pan for coarse and fine filling.
- High amplitude vibratory feeder with stroke of max. 9 mm.
- Filling straight into the box and weighing on a scale underneath the carton.

Gross filling directly into the box

- Reduces drop height.
- Offers a more constant product filling.
- Prevents product from sticking in a weigh hopper.

Products up to 100 x 100 x 100 mm

- Dehydrated products with very low density.
- High volume products needing a high amplitude such as margarine flakes and dehydrated & sliced fruit.

Standard equipped with

- Integrated scale
- Colour touch panel
- Stainless steel support frame



Coarse and fine filling

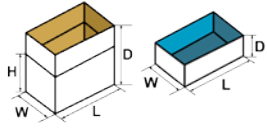

Filling straight into the box

CONTAINER SPECIFICATIONS (For other dimensions, please contact Pattyn)	
Type	Cases, trays, plastic crates...
Range (L x W // D) mm	Min. 300 (L) x 200 (W) // 100 (D) Max. 800 (L) x 500 (W) // 650 (D)
	 <p style="text-align: right;">Outside dimensions</p>
OUTPUT AND CONSUMPTION	
Output	Up to 5 c/m (depending on product and weight)
Product diameter size	Max. 100 x 100 x 100 mm
Installed power	3 kW
Voltage	3 x 400 V + N + E / 50 Hz
Air supply	6 bar / 1/8" min
Air consumption	1 NI / cycle
Weight	625 kg
OPTIONS (More options are available, please contact Pattyn)	
	Dimple plate execution
	Heating element to prevent condensation
	Access point for remote support

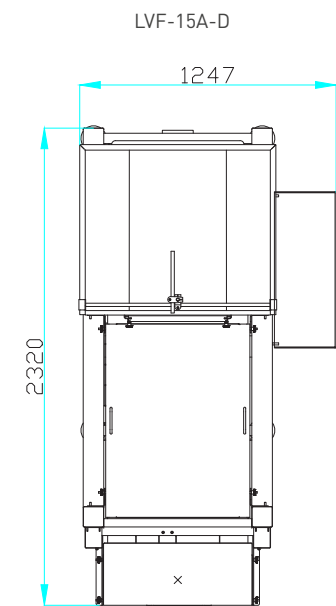

Machine height 2214 mm

Machine height as reference only,
depending on case dimensions

**Accuracy depends on the product and capacity.
For more details or specific requirements, please contact us.**

Pattyn Packing Lines nv
Industriepark 'Blauwe Toren'
Hoge Hul 2, 8000 Brugge - Belgium

T +32 (0) 50 450 480
info@pattyn.com
www.pattyn.com



The description, pictures and information given have an indicative value. We reserve the right to make changes without notice. Information and content is property of Pattyn. For customised executions please contact Pattyn. LVF-15A-D 2018 - V01

PATTYN®

Turnkey solutions for industrial packaging.